

The FP-FRI-1X2 Line array kit give designers, contractors and audio consultants the ability to create a two FRI122+ or FRI152+ speaker in a tight pack configurations. The FasPac™ provides a method of flying a tight pack array while offering the capability of allowing cabinets to be adjusted relative to each other to find the optimum sound directivity. A series of holes are provided to easily adjust the splay angle from 0° to 30° at an increment of 2.5 degree.

Installing speakers must be performed by experienced professionals. If in doubt about the integrity of the structure you are mounting or suspending to or not sure about the proper hardware or method to use, consult a certified rigging company.

Package contents:

- 4 pcs 6-0101 Front Joiner Plate
- 8 pcs Btnhd sckt screw, 3/8-16x1.5" long
- 12 pcs 3/8 flat washers

CAUTION: PLEASE READ CAREFULLY BEFORE PROCEEDING

Due to the wide variety of building structures, materials and suspension methods, these instructions assume that the installing contractor/installer will exercise good judgment in selecting the proper mounting area and hardware. As a guide, the installation, when complete, should be capable of supporting at least 5 times the actual load. Follow building code requirements to safely suspend the speakers to the building structure

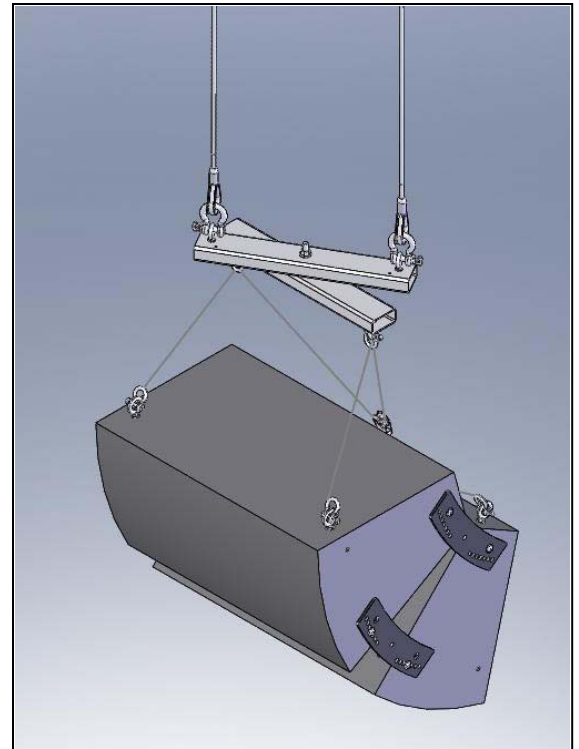

Step 1.

Unscrew existing speaker screw and discard.

Step 2.

Determine the splay angle of the speaker and the holes to use on the front joiner plate (Figure 2).

Step 3.

Install the front joiner plate on rear rigging inserts of the speaker using the slots of the plate (Figure 1). Install another front joiner plate on the two front rigging inserts using the corresponding holes for the appropriate splay angles. Use the provided 3/8 screws and washers. Make sure the markings on the plates are facing up. Do not tighten screws; leave it snug until all plates are in position.

Step 4.

Slowly flip the speaker assembly up then repeat Step 3.

Step 5.

When all plates are in position, tighten all screws permanently.

Step 6.

Lay the speaker cluster on its side then install eyebolts to the side rigging points (now top) of the speaker as shown (Figure 3). Install eyebolts on the rear rigging points of the lower speaker.

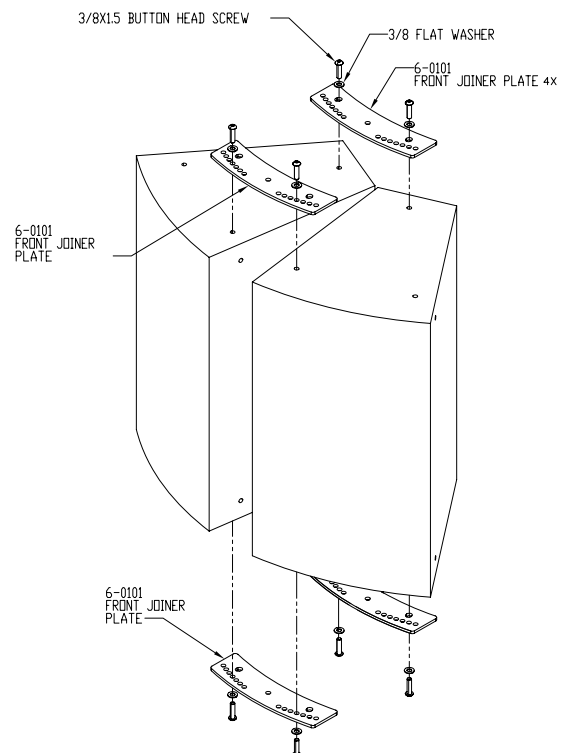

Figure 1

Step 7.

Use the eyebolts on the top of the speaker cluster as the main speaker suspension points. Use the lower eyebolts on the lower speaker for pull back points to adjust the tilt angle of the speaker cluster assembly (See main illustration).

Step 8.

Check all hardware connections before hoisting cluster.

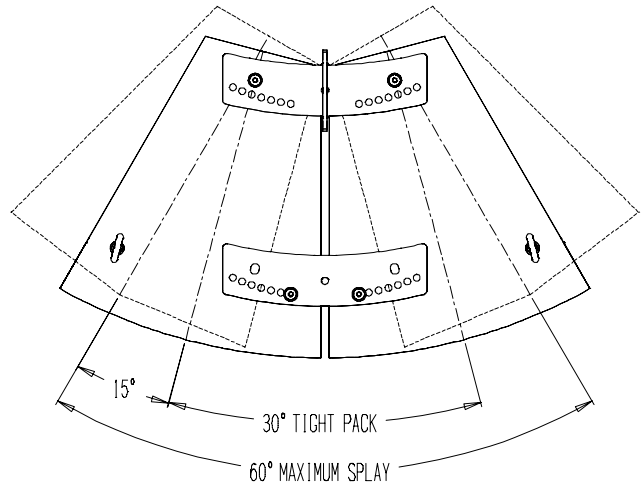

Figure 2.

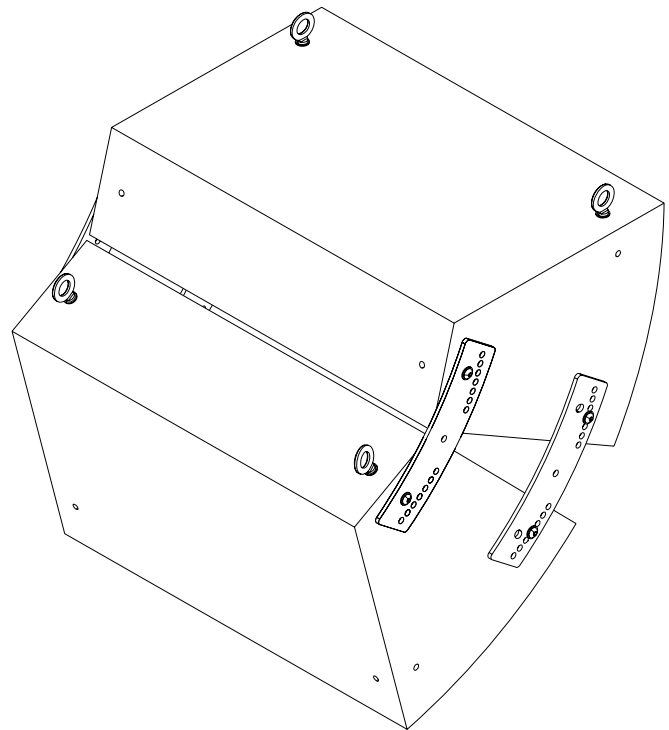

Figure 3.