

STEP KIT RS-VLA-i-301-SB

3200 lb. WLL

VLA301i to VLA601i STEP BRACKET KIT

RIGGING SYSTEM



RS-VLA-i-301-SB STEP BRACKET KIT

Use this precision manufactured adapter Strap Kit to step down from the longer VLA301i speaker cabinet to the shorter VLA601i speaker cabinet.

This adapter locks in just like the standard Strap Kits using the same interlocking features. Splay angles are also provided via the step bracket where VLA601i cabinets can be tight-packed up to the VLA301i cabinet or splayed out, up to 10 degrees.

Attaching the VLA601i cabinet underneath the VLA301i cabinet provides additional near field coverage.

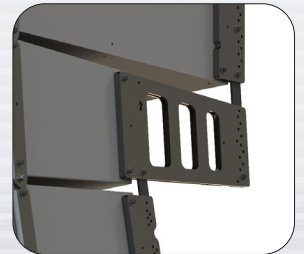

STANDARD FEATURES:

- ▶ Bridges VLA601i speaker under the VLA301i speaker
- ▶ Supports VLA301i & VLA601i Loudspeakers
- ▶ Secures to upper and lower strap kits
- ▶ Supports Permanent Installations

OPTIONAL ACCESSORIES:

- ▶ See overhead hardware data sheet
- ▶ See wire rope data sheet

SPECIFICATIONS:

Materials: Structural steel
Finish: Powder coat
Color: Black
Tilt Angle: 10° degrees
WLL: 3200 lb / 1455 Kg
Design Factor: 5:1

PACKAGE CONTENTS:

2 pcs. Front Straps and hardware
2 pcs. Rear Straps and hardware
2 pcs. Rear links and hardware

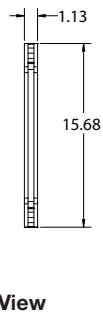
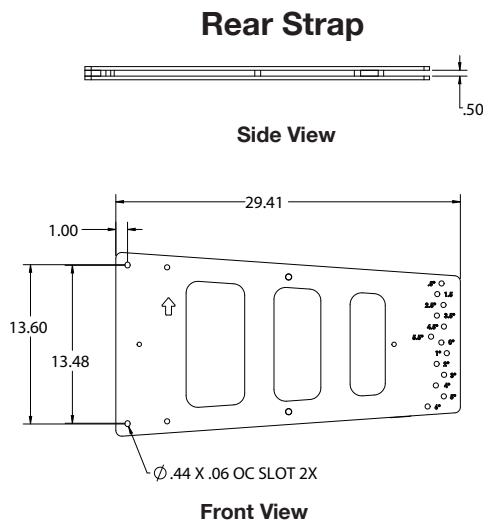

Front Strap

