

PC-3725-15A

265 lbs.

STACKABLE PROJECTOR FRAME

Fly-Ware®



Mount projectors rigidly and quickly to Adaptive Fly-Ware's Rigging Frame then fly them safely from under trussing, bolted under strut or suspended using wire rope.

These sturdy structural frames are fabricated from tough tubular aluminum alloy and stronger than what is found in service today, they are road tested and can handle the wear and tear of the rental and staging world.

Once in the air, aim the projector in all three axes using the fine-adjust controls at the back of the frame. Adaptive's Fly-Ware Projector Frames are stackable too, up to three high, and they mate with other brands that are already in service.



Stackable up to 3 high

FEATURES

- ▶ Suspend from Truss, Strut or Wire Rope
- ▶ Stacks up to Three High
- ▶ X, Y and Z Fine Adjustments
- ▶ Stackable with other brands
- ▶ Black Powder Coated Finish
- ▶ Light Weight Aluminum Construction

OPTIONAL ACCESSORIES:

- ▶ Tandem Truss Clamp MC-2X1.5-TNDM-B

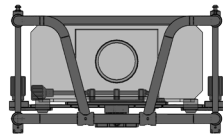

Pan Angle Adjustments

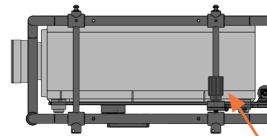

Left / Right Tilt / Slope Adjustment

SPECIFICATIONS:

- Materials:** Aluminum alloy
- Finish:** Powdercoat
- Color:** Black
- WLL:** 265 lbs./ 120 Kg.
- Design Factor:** 5:1 ratio
- Net Weight:** 85 lbs./ 38 kg.
- Max Stacking:** Up to 3 frames
- Max Projector Size:** 37" Long, 25" Wide, 15" High

DIMENSIONS:

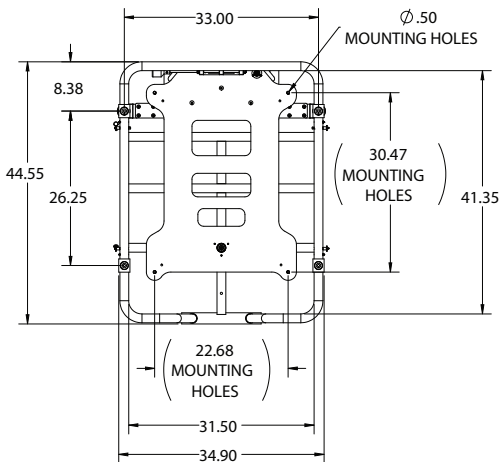

Top View

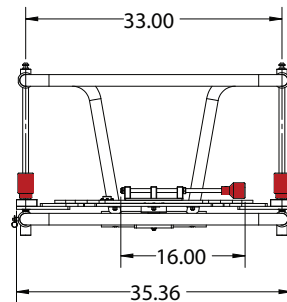

Back View

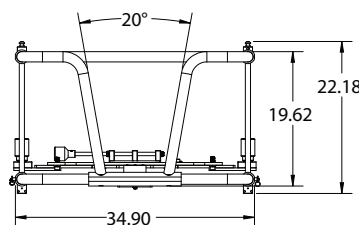

Front View

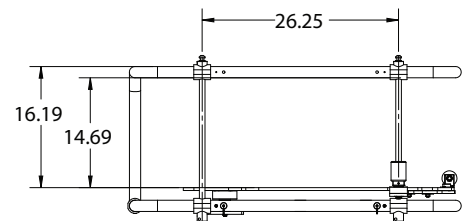
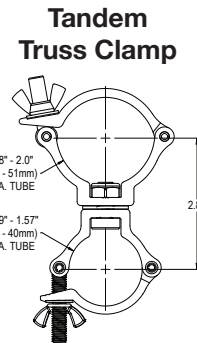

Side View



ALWAYS INSTALL SAFETY CABLES

WARNING: Mounting and/or suspension of audio and video equipment requires experienced professionals. Improperly installed equipment can result in property damage, personal injury and/or liability to the installing contractor.

