



# MP-1.5NPS-TA

## Tube Adapter Installation Guide

The MP-1.5NPS-TA is a tube adapter that connects a standard 1-1/2x11-1/2 NPS pipes to U-channels. This adapter allows speakers to be mounted to U-channels using standard 1-1/2x11-1/2 NPS pipes.

**Warning:**  
Mounting and/or rigging loudspeakers requires experienced professionals. *Improperly installed loudspeakers can result in property damage, personal injury, death and/or liability to the installing contractor.*

To assure a trouble free installation, read through and follow these instructions carefully before beginning. If you have doubts about the integrity of the structure you are mounting to or the proper mounting hardware, consult a local structural or hardware specialist.



Be sure that all of the following items are included in this kit before proceeding:

Qty.	Description
1 pc	Tube Adapter, 1-1/2x11-1/2NPT/NPS
1 pc	Instruction sheet
2 PCS	Flange bolt, 1/2"-13x1.5", blk
2 pcs	Flat washer w/ neoprene, 1/2"
2 pcs	Channel retainer nut, 1/2"-13

**Step 1:**  
Install tube adapter to U-channel using the provided flange bolt, flat washer with neoprene and channel retainer nuts. First, insert the channel retainer nuts inside the U-channels then line up the holes of the tube adapter to the threaded holes of the channel retainer nuts. Secure tube adapter to U-channel with the flange bolts and flat. Slide and position the tube adapter to desire location along the U-Channels then tighten Flange bolts permanently (Figure 1).

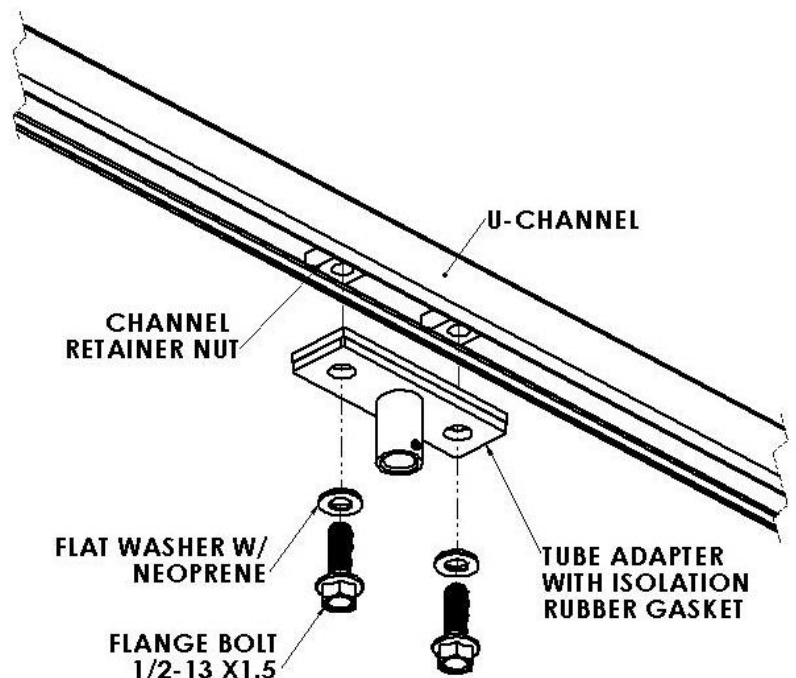

Figure1

## Step 2: Install Pipe

Loosen the set screw on the tube adapter's coupling.

Thread the 1-1/2x11-1/2 NPS or 1-1/2x11-1/2 NPS or 1-1/2x11 BSPT Pipe into the threaded hole of the tube adapter. At least 1/2" of the pipe threads should go in. Use a wrench to fully secure pipe to tube adapter. Tighten set screw to permanently lock pipe (Figure 2).

## Step 3:

Refer to the Pipe kit and Ceiling Mount kit Installation guide to complete the installation.

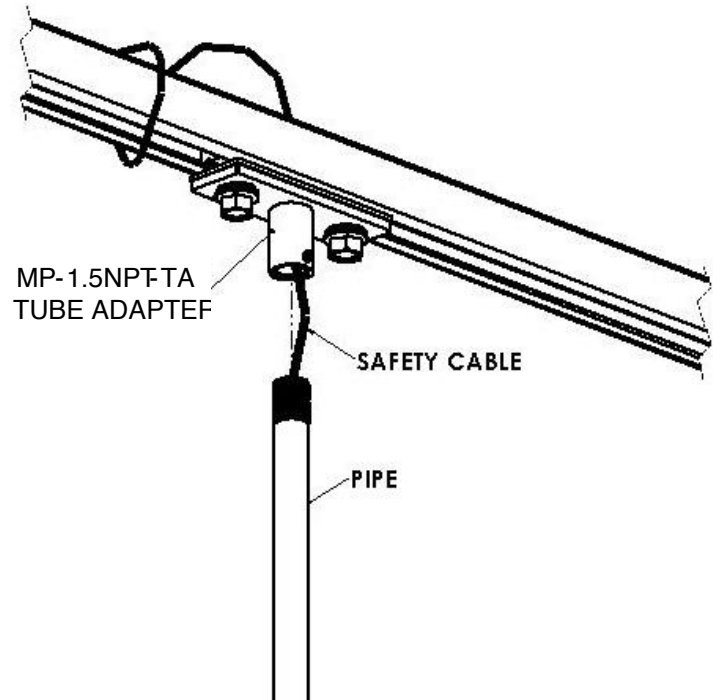

Figure2