

FEATURES:

- Build up to 26' Wide x 15' Tall walls
- Fast set ups and dismantling
- Light-weight aluminum construction
- Telescoping T-Base floor module
- Telescoping Back Support Brace
- Adjustable floor levelers
- Built in X and Z axis bubble levels
- Rugged black powder coat finish
- Aircraft pins for quick assembly
- Ballast anchor points and tie downs
- Rolling cart with 6" locking casters
- Fits inside delivery truck width-wise
- Optional Cart top converts to table
- Easy to use ballast calculator
- Fork Lift Compatible
- Supports LED tiles
500 X 500mm & 500 X 1000mm

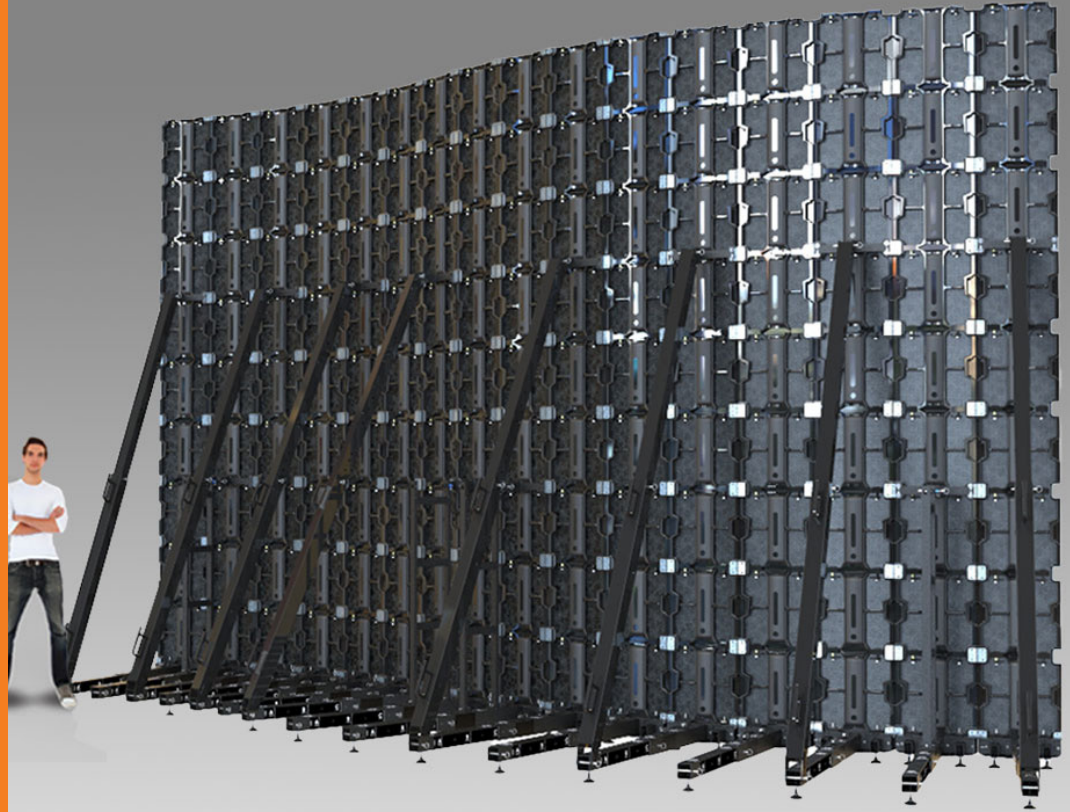

Quickly Assemble Straight and Curved Video Walls

This innovative ground support system includes everything you need to set up LED video walls. Quickly build up to 16 LED tiles wide and 9 LED tiles tall using 500 mm LED monitors or add the Dual Column System for more configurations. Loc-N-Load® sets up and packs up in half the time that it takes using conventional ground support methods.

The Loc-N-Load's telescoping T-Base supports single columns of LED tiles (up to 9 high). They connect to the next T-Base and to the next, etc. Each T-Base is equipped with three leveling gliders as well as X and Z axis bubble levels so your crew can get the first tier of monitors locked into a level plane quickly.

The telescoping Back Brace connects to the back of the every other T-Base and extends upward to the 4th, 5th and 6th tiers as the T-Base extends outward. This provides a higher reach and an anchor point to the upper tier monitors as the video wall grows higher.

When dismantled, all of the T-Bases, Back Braces and Back Stays quickly stow onto its rolling cart. Cart weight fully loaded is less than 1150lbs.



Rolling Cart

Compatible LED Tiles

LEDs used on Single Column T-Bases must interlock with each other. T-Bases serve only as a leveling platform for LEDs.

In-line Connection

Connect multiple LED tiles in a straight line



Dual T-Base Single T-Base

Convex / Concave Curve

Connect LED tiles in a convex or concave curve, tile-to-tile up to 5° +/-*



T-Bases - Curved Connection

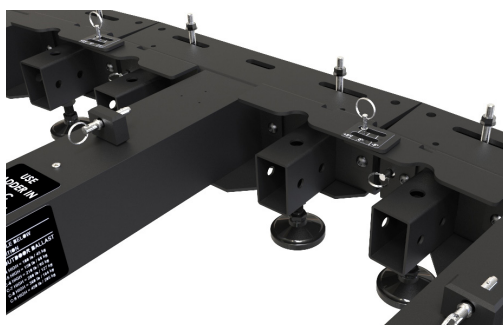

T-BASE Connection

CONVEX CURVE

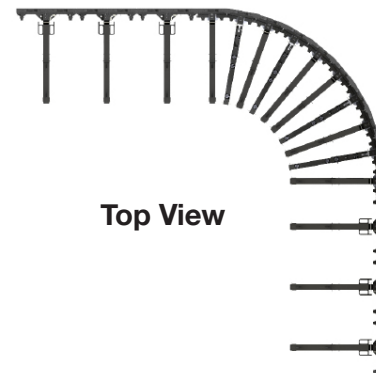
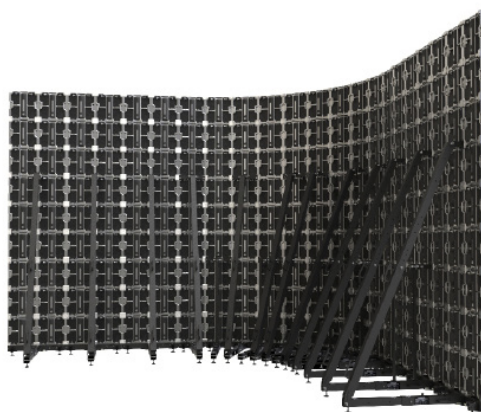

Top View

This is a typical example of a video wall display utilizing both Single-Column and Dual-Column T-Bases. Single-Column T-Bases form the curve with the LED monitors facing out and the Dual-Column T-Bases continue the straight sections.

CONCAVE CURVE

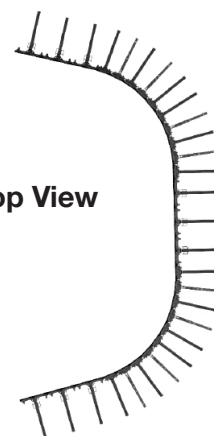
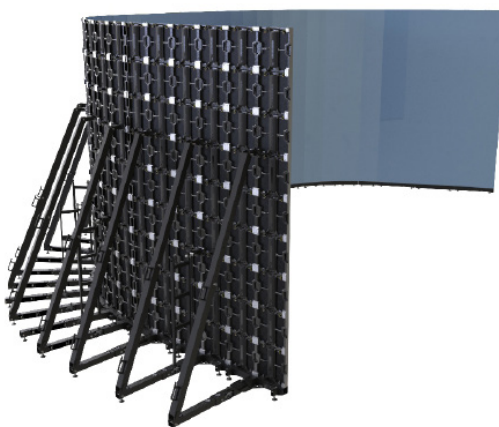

Top View

Like the Convex configuration, this is a typical example of a concave video wall display utilizing both Single-Column and Dual-Column T-Bases. Single-Column T-Bases form the curve with the LED monitors facing in and the Dual-Column T-Bases continue the straight sections.

*tile to tile angle and wall radius dependant upon selected LED model

Rear Supports



Ladder Support GS-LADDER-5

This 5-foot tall Brace connects to the T-Base and Back-Stay to support 5-high video walls.

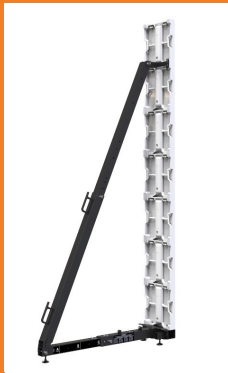

Telescoping Brace Support GS-BRACE

This Brace connects to the T-Base and Back-Stay to support video walls ranging in height from 6 monitors high to 9 monitors high.



Brace and Ladder Support

If the selected LED tile lacks rigidity or is subjected to wind, use both the Ladder Support and Telescoping Brace Support when stacking 7, 8 or 9 tiles high.

T-Base Connections

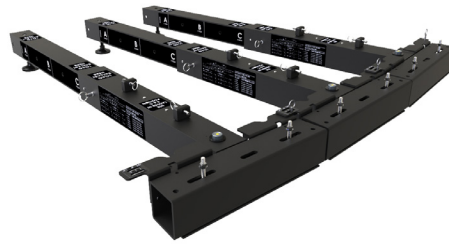

Single Column LED Connection

The T-Base serves as a leveling platform that supports vertical columns of LED monitors. The selected LED must be an interlocking design as they support the columns from left to right. Form any configuration straight or curved display, up to 5° depending on the selected monitor.

*Use Dual-Column T-Bases for straight sections to save time and use fewer components.

Single Column Telescoping T-Base



GS-T-BASE-500S

Connect bases to other bases side by side as needed, in-line or in a curve. Each base accommodates a 500mm x 500mm LED monitor. Build vertical columns up to 4500mm tall. The base telescopes out as the video wall gets taller. A bubble level and adjustable feet provide fine-tune leveling.

Telescoping Back Brace

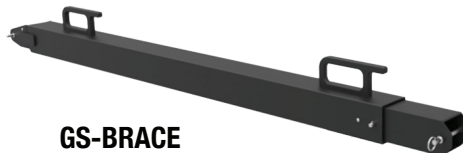

GS-BRACE

Support video walls six or more monitors high (3000 mm +). Its lower clevis-style brace connects to the T-Base. Its top connects to the universal back stay using an adapter plate that secures to the LED tile. Ballast handles are used to hang sand-bags for ballast or to strap down to decks.



Back Brace Connection to T-BASE

Optional Accessories

Short Wall Support - GS-LADDER-5



Blank Tile Spacer 500 mm X 500 mm
GS-BT-500X500



Blank Tile Spacer 500 mm X 1000 mm
GS-BT-500X1000

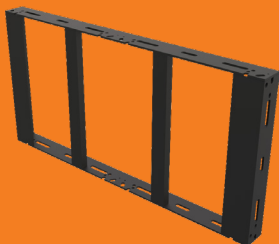

Back-Stay Connections

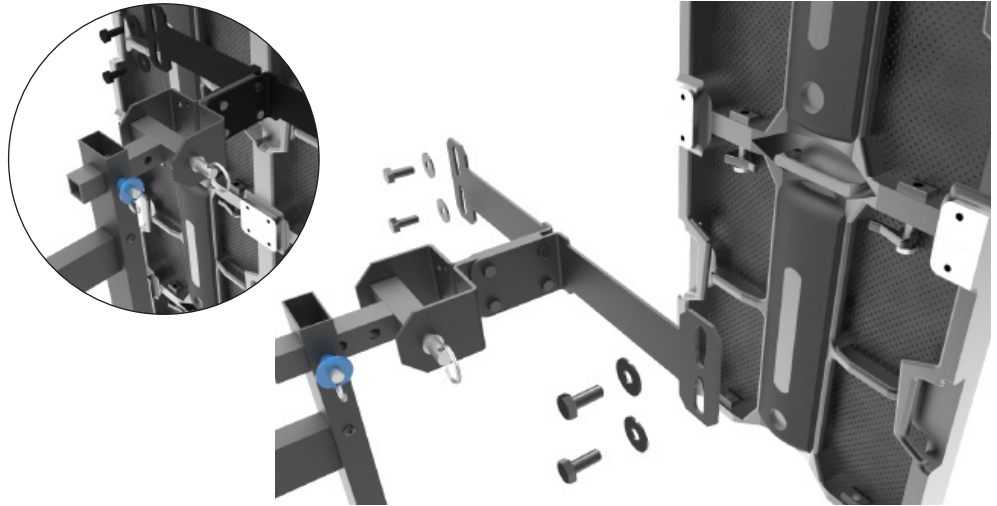

The Back-Stay connects to the LED tile via the only non-universal component in the system, an LED adapter. It connects to both Support Ladders and Telescoping Brace Supports to the LED tile via a unique tile-specific adapter. Both require this adapter to bridge between the back support and the selected LED monitor. If your selected LED is not listed, contact customer service at sales@adaptivetechologiesgroup.com or call 562-424-1100.

Universal Back Stay and LED Adapter Bracket Assembly

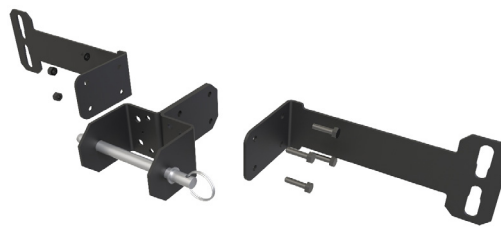

Universal Back Stay GS-BCKSTY-DS



[Click here for a list of LED adapters](#)

Model Specific LED Adapters



Optional Accessories

Cart Cover (GS-CART-CVR)

Save space on the truck or warehouse. This rugged Cart Cover interlocks with the cart and built from a black painted aluminum frame and thick plywood top.



Folding Table & Cover (GS-CART-TABLE)

This cover design opens into a convenient work bench for tools and wiring. It interlocks with the cart and comprised of a black painted aluminum frame, plywood top and folding legs. It measures 84" long X 34" wide X 30" tall.



Cart Stacker (GS-CART-IF)

Save space in the warehouse by stacking a fully loaded cart atop another cart with a fork lift using this black painted sturdy aluminum frame. **This product is not to be used during transport.**



Rolling Cart GS-CART-SNGL

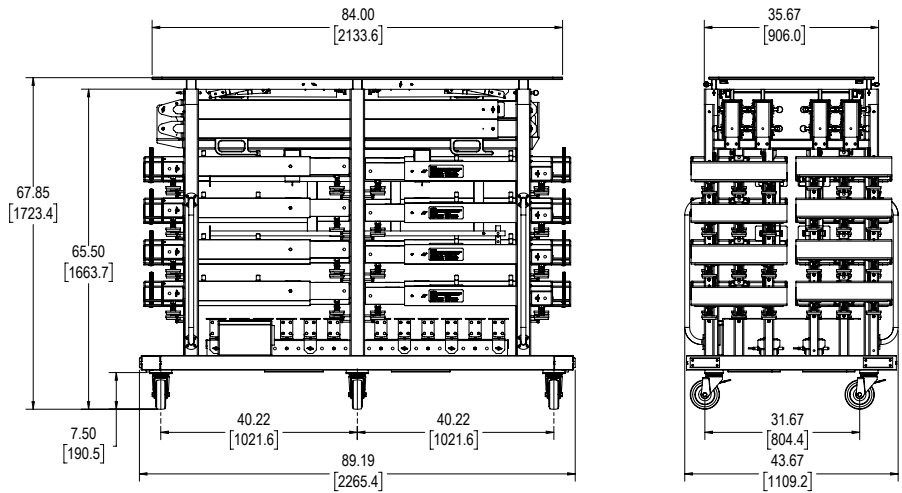

Loc-N-Load® Rolling Cart

The Loc-N-Load's Rolling Cart holds all of the ground support components necessary to assemble a 16 wide by 9 high LED tile video wall. This rugged Cart's tubular aluminum frame stows 16 telescoping Single-Column T-Bases, 8 telescoping Back Braces and 4 five foot high Support Ladder assemblies.

It comes in a black powder coat finish and rolls on six 6" locking casters. Corner bumpers protect its frame during transport and all its ground support components lock into the cart using quick release fasteners.

The optional removable top converts into a set up table and provides a way to stack additional gear. Its length stows inside a delivery truck length-wise, up against the cab.



A, B and C Positions

The Loc-n-Load® interlocking ground support system has three positions that the telescoping T-Base and back brace lock into as rows of monitors are added.

After laying down the T-Bases and locking them together, you can set 4-5 rows of monitors utilizing the A position. Add a 6th row of monitors and extend the t-base and back brace into the B position. Add a 7th row of monitors and extend the t-base and back brace out to the C position. Once in the C position you can add an additional 2 rows of monitors for the maximum height.

Always load counter balancing ballast when assembling the Loc-n-Load® video walls. Look for the "Load Ballast Here" labels.



WARNING:

BALLAST WEIGHT MUST BE ADDED DURING ASSEMBLY. SEE WEIGHT TABLE BELOW FOR OUTDOOR APPLICATIONS THE T-BASE MUST BE IN THE C POSITION

A-INDOOR BALLAST	B-INDOOR BALLAST	C-INDOOR BALLAST	C-OUTDOOR BALLAST
A-4 HIGH = 80 lb / 36 kg	B-4 HIGH = 60 lb / 27 kg	C-4 HIGH = 50 lb / 23 kg	C-4 HIGH = 100 lb / 45 kg
A-5 HIGH = 120 lb / 55 kg	B-5 HIGH = 90 lb / 41 kg	C-5 HIGH = 75 lb / 34 kg	C-5 HIGH = 150 lb / 68 kg
A-6 HIGH = 170 lb / 77 kg	B-6 HIGH = 130 lb / 58 kg	C-6 HIGH = 105 lb / 48 kg	C-6 HIGH = 210 lb / 95 kg
A-7 HIGH = 230 lb / 105 kg	B-7 HIGH = 175 lb / 80 kg	C-7 HIGH = 140 lb / 64 kg	C-7 HIGH = 280 lb / 127 kg
A-8 HIGH = 290 lb / 132 kg	B-8 HIGH = 220 lb / 110 kg	C-8 HIGH = 180 lb / 82 kg	C-8 HIGH = 360 lb / 164 kg
A-9 HIGH = 360 lb / 164 kg	B-9 HIGH = 280 lb / 127 kg	C-9 HIGH = 230 lb / 105 kg	C-9 HIGH = 450 lb / 205 kg

Outdoor working loads are based on a maximum of 40 mph to the back of a fully assembled 16X9 Video Wall.

Rear Support & Ballast Positioning

