

BC-2824-12

180 lb WLL

LOW PROFILE OFFSET BEAM CLAMP

BeamWare®



Beam Clamp & Isolator Supporting a Grid

BEAM CLAMP

Standard, pre-engineered channel style beam clamps anchor to a building's structure and offer a safe and predictable method of rigging grids and other objects from overhead. This hook style beam clamp is adjustable and mounts flush underneath the building's I-Beam's flange. Use the BC-2824-series hook style beam clamp to provide a load rated overhead rigging point from structural I-Beams with widths ranging between 2" and 6", 6" and 9" or 9" and 12".

This beam clamp model provides a fast, easy and safe way to rig direct loads, bridles and hitches from overhead and a hand wrench is all that is required to secure this clamp. The beam flanges must be parallel to the floor. secure this clamp. The beam flanges must be parallel to the floor.



I-Beam Clamp with Sound Isolator



KEY FEATURES:

- ▶ For beam flange widths between 9" and 12"
- ▶ Accommodates 1/2" - 13 threaded rod.
- ▶ For overhead vertical suspension applications.

OPTIONAL ACCESSORIES:

- ▶ See Threaded Rod [ROD-500-XXX](#)
- ▶ See Strut Accessories Datasheet
- ▶ See Sound Isolation [CG-SH-1-245-IH](#)

SPECIFICATIONS:

Material: Structural Steel
Grade B7 Threaded Rod

Finish: Bright Zinc

Color: Silver

Design Factor: 7:1

WLL: 178.5 lbs / 81.1 Kg

Shipping Weight: 1.9 lbs / .78 Kg

PACKAGE CONTENTS:

1 pc Beam Clamp
6 pcs Hex Nut, 1/2"-13
1 pc 12" All Threaded Rod



Front View

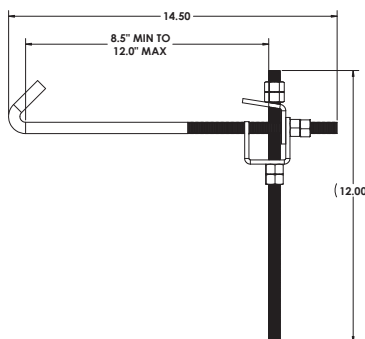

Side View

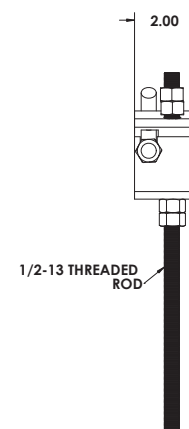

Adaptive Technologies Group
1635 E. Burnett Street | Signal Hill, CA 90755 USA
Ph: 562.424.1100 | Fax: 562.424.3520
www.adaptivetechgroup.com



ALWAYS INSTALL SAFETY CABLES

WARNING: Mounting and/or suspension of equipment requires experienced professionals. Improperly installed equipment can result in property damage, personal injury and/or liability to the installing contractor.