

# AJ-1524-BT

60 lb WLL

ADJUSTABLE WIDTH U-BRACKET WALLS & CEILING MOUNT

UB-SERIES



Wall Mounted

Adjustable Loudspeaker Mounting Kits support most of the mountable loudspeakers in the 60 lbs./27 kg. range, or less and its open side arm slots allow a single installer to easily mount loudspeakers in this weight range. Loudspeakers can be rotated within the arms to acquire the desired tilt angle. Separate side holes permit the angle of the speaker to be locked permanently using lag bolts. Since there are only two sizes, inventory requirements are minimal.

Fully captive arm holes permit safe, secure mounting of loudspeakers under balconies, overhangs and from ceilings. The brackets' base gives installers multiple options for placing speakers over irregular and unpredictable mounting surfaces because of its unique mounting slot pattern.



Ceiling Mounted

## STANDARD FEATURES:

- ▶ Packed in pairs
- ▶ Two models support most loudspeakers, weighs 60 lbs/27 kg. or less
- ▶ 16" and 24" hole centers match wall studs
- ▶ Open arm slots for one man installation
- ▶ Sound isolation gaskets block sound transmission through walls
- ▶ Permanent angle set capable

## OPTIONAL ACCESSORIES:

- ▶ UB-M06-BC hardware
- ▶ UB-M08-BC hardware
- ▶ UB-M10-BC hardware
- ▶ Safety cables

## SPECIFICATIONS:

- Material:** Structural Steel Alloy
- Down Tilt:** Up to 60 degrees
- Finish:** Powder Coat
- Color:** Black
- WLL:** 60 lbs. (27 Kg) max.
- Design Factor:** 7:1 ratio



Rated for indoor use.

## CONTENTS:

- ▶ Includes an assortment of 1/4", 5/6" and 3/8" bolts and hardware plus two 1/4" thick sound isolation gaskets.
- ▶ One pair bracket sets

## ALWAYS INSTALL SAFETY CABLES

**WARNING:** Mounting and/or suspension of equipment requires experienced professionals. Improperly installed equipment can result in property damage, personal injury and/or liability to the installing contractor.

# AJ-1524-BT

# 60 lb WLL

ADJUSTABLE WIDTH U-BRACKET WALLS & CEILING MOUNT

**UB-SERIES**

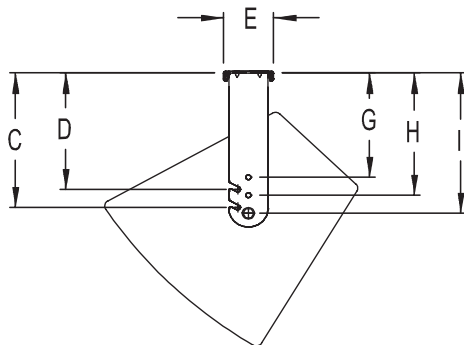

**Side View**  
(ceiling application)

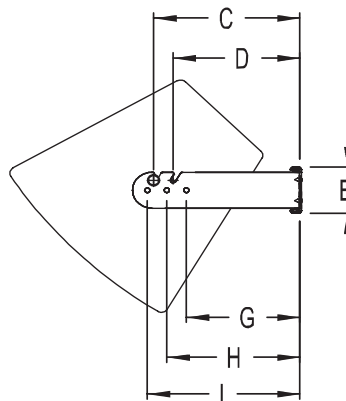

**Side View**  
(wall application)

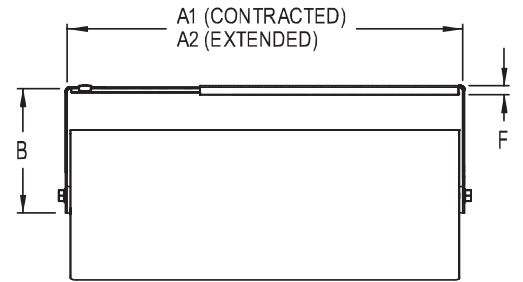

**Top View**

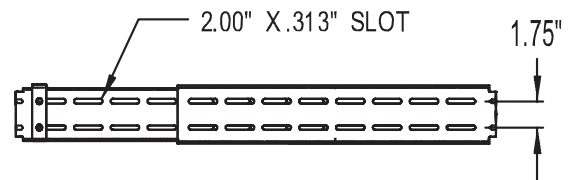

**Back View**

**DIMENSIONS: INCHES / METRIC**

**AJ-1524** Arms adjust from 15" to 24"

A1	A1	B	C	D	Net Weight
15" / 381	24" / 609	11.1" / 283	9.5" / 241	8.0" / 203	5.8 lbs / 2.6Kg

E	F	G	H	I	Ship Weight
3.38" / 86	3.38" / 86	6.9" / 175	8.5" / 216	9.9" / 251	12 lbs / 5.5Kg

**Adaptive Technologies Group**  
1635 E. Burnett Street | Signal Hill, CA 90755 USA  
Ph: 562.424.1100 | Fax: 562.424.3520  
www.adaptivetechgroup.com



**ALWAYS INSTALL SAFETY CABLES**

**WARNING:** Mounting and/or suspension of equipment requires experienced professionals. Improperly installed equipment can result in property damage, personal injury and/or liability to the installing contractor.