

# AMFS-1X2-SME

## Shackle Mount Extended

### Installation Guide for AMFS-1X2-SME

Thank you for choosing the AMFS-1X2-SME Shackle Mount Extended. The AMFS-1x2-SME is an accessory hardware to the AMFS-1x2 series truss module. The AMFS-1x2-SME provides three attachment points for loudspeaker suspension, and provides tilt angle control for the speaker.

**Important:** Rigging overhead system requires professional experience. **Improperly installed equipment can result in property damage, personal injury, death and/or liability to the installing contractor.** Do not suspend if in doubt about the integrity of the structure.

**Caution:** Due to the wide variety of structures, environments, materials and rigging methods, these instructions assume that the installing contractor will exercise good judgment in selecting the proper mounting area and hardware.

**Follow these instructions for the most efficient and safest mounting results.**

**Do not exceed the working load limit of 496lbs/225 kg.**

#### Package Contents:

- 1 pc. AMFS-1x2-SME
- 1 pc. Instruction sheet
- 1 pc. Nylock Nut, 3/8-16,G8
- 2 pcs. Flat washer, 3/8",USS
- 1 pc. Hex bolt, 3/8-16x3",G8

#### Step 1. Install the AMFS-1x2-SME Shackle Mount Extended For Permanent Installation:

Install the shackle mount extended to the selected holes of the 1x2 truss module using the included 3/8 X 3" hex bolt, washers and nut. Hole placements will affect the tilt angle of the speaker. Tighten permanently (Figure 1).

#### For Temporary Installation:

Install the shackle mount extended to the selected holes of the 1x2 truss module using a 3/8" x 2.5" long quick release pin. Quick release pin sold separately (Figure 2). Make sure the pins goes all the way to the other side of the tube.

#### Step 2. Suspend Speaker cluster:

Secure a suspension hardware (i.e. carabiner or shackle) to one of the shackle mounts holes (See main picture). Hole placements will affect the tilt angle of the speaker.

#### Step 4.

Check all connections before suspending the speaker cluster.



AMFS-1x2-SME Shackle Mount Extended using Quick Release Pin

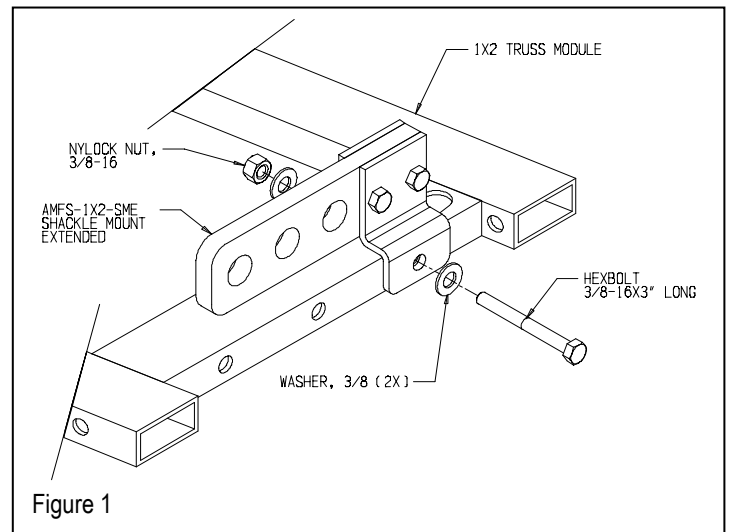

Figure 1

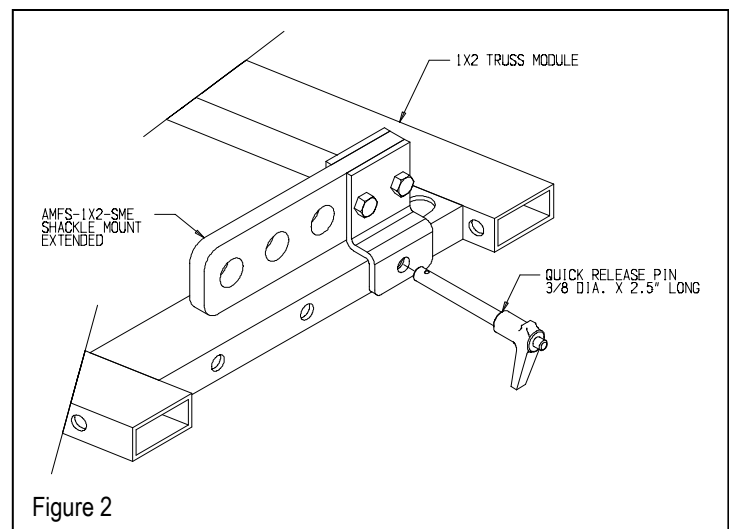

Figure 2