

PULL-BACK CHAIN

2800 lb WLL

Single Point & Bridled Pull-Back Chain

Rigging Hardware

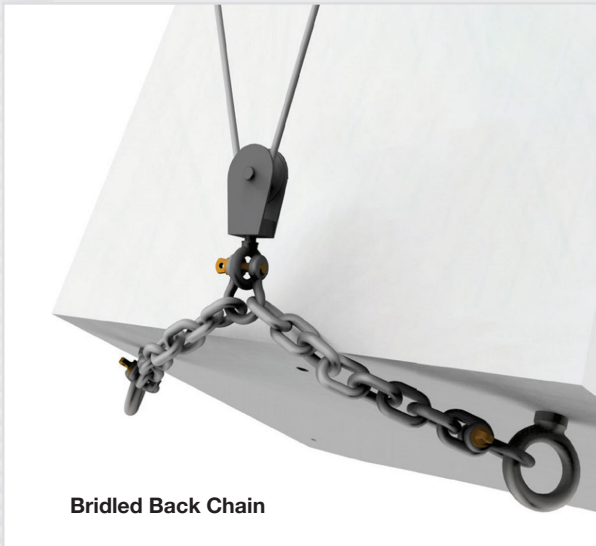

Bridled Back Chain

Single Point & Bridled Pull-Back Chain

The primary purpose for using the Back Chain assembly as a pull-back is when the pick up or lifting point of a load reaches around an edge or corner where the possibility of chaffing or kinking of wire rope exists.

This very simple and inexpensive solution attaches easily to wire rope assemblies, Eye bolts, Eye-nuts, Carabiners and Quick-links.



Single Point Back Chain

STANDARD FEATURES:

- ▶ Prevents wire rope chaffing and kinking
- ▶ Comes with SPA Shackle

OPTIONAL ACCESSORIES:

- ▶ See Eyebolts / Eyenut datasheet
- ▶ See SPA Shackle datasheet
- ▶ See Tilt Cable datasheet

SPECIFICATIONS:

Materials: 9/32 - Grade 80
Finish: Black Oxide
Color: Black
WLL: 2800 lb / 1272 Kg
Design Factor: 5:1

PACKAGE CONTENT:

1 pc: Rigging Chain
1 pc: SPA Shackle
1 pc: Cable Tie



MADE IN USA

Rated for indoor use.

BACK CHAIN OPTIONS AND DIMENSIONS:

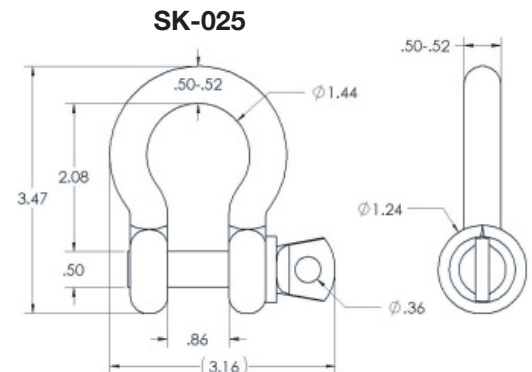
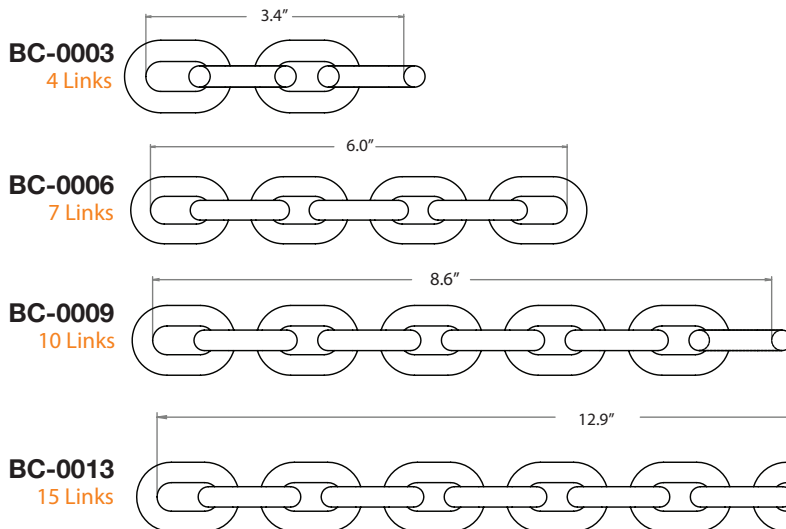

ALWAYS INSTALL SAFETY CABLES

WARNING: Mounting and/or suspension of audio and video equipment requires experienced professionals. Improperly installed loudspeakers can result in property damage, personal injury and/or liability to the installing contractor.