

# BC12-17

# 385 lb WLL\*

## LOW PROFILE BEAM CLAMP WITH SWIVEL EYE

## BeamWare®



Swiveling Hang Point

### CHANNEL STYLE BEAM CLAMP

Adaptive's low-profile channel style beam clamps anchor permanently to structural I-Beams and provide a safe, predictable method for suspending loads from overhead.

The channel style beam clamp is adjustable for beam flange widths ranging from between 12" and 17" (305-432mm). The body of the clamp mounts flush underneath the beam's flange and is equipped with a load-rated swiveling shoulder eye bolt that rotates in the direction of the load to minimize side loading.

Specify this beam clamp for many types of suspensions from horizontally oriented I-Beams, including wire rope assemblies, bridles, rigging chain and other equipment.

A variety of spacers are included in the kits to accommodate beam flange thickness from .1875 to 1.0" (5mm to 25mm) and the only tools that are needed to install the clamp is a 1.0" and a 7/16" hex wrench.



Wood Beam Adapter  
BC-LAM-KIT

\* Steel I-Beams Only

### KEY FEATURES:

- ▶ Single load-rated center suspension
- ▶ Provides safe load-rated hang point to 45° off center.
- ▶ Secures to beam flanges ranging from 12" - 17"

### OPTIONAL ACCESSORIES:

- ▶ See Wire Rope Datasheets
- ▶ See Rigging components Datasheets
- ▶ BC-LAM-KIT for wooden beams

\* Not for human suspension

### SPECIFICATIONS:

**Materials:** All Steel Components  
**Width:** 12" to 17" / 305mm to 432mm  
**Finish:** Powder Coat  
**Color:** Black  
**WLL:** 385 lb/175 kg  
**WLL:** 45 DEG. WL: 100 lb / 45 kg Steel I-Beams  
**WLL:** 300 lb / 136 kg max on wooden beams  
**Design Factor:** 5:1  
**DO NOT EXCEED 45° off hang points**  
**Weight:** 10.6 lb / 4.8 kg

### PACKAGE CONTENTS:

1 pc Beam Clamp Channel  
2 pcs Locking Angle Plate  
2 pcs Flat Washer, 5/8"  
2 pcs Nyloc Nut, 5/8-11



Rated for indoor use.

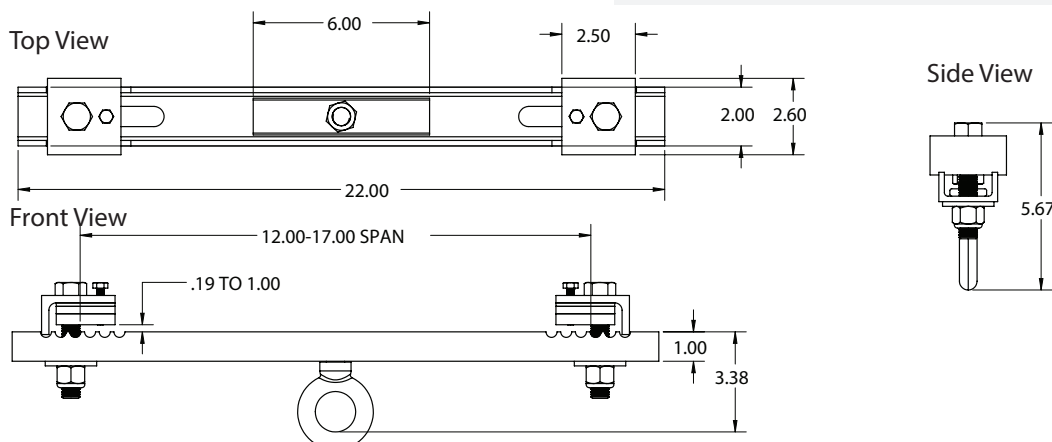

**Adaptive Technologies Group**  
1635 E. Burnett Street | Signal Hill, CA 90755 USA  
Ph: 562.424.1100 | Fax: 562.424.3520  
www.adaptivetechnologiesgroup.com



### ALWAYS INSTALL SAFETY CABLES

**WARNING:** Mounting and/or suspension of equipment requires experienced professionals. Improperly installed equipment can result in property damage, personal injury and/or liability to the installing contractor.