

# CG-P1045-ZB

# 779 lb. WLL

VIBRATION ISOLATED CHANNEL STRUT CROSS OVER KIT

STRUT ATTACHMENT

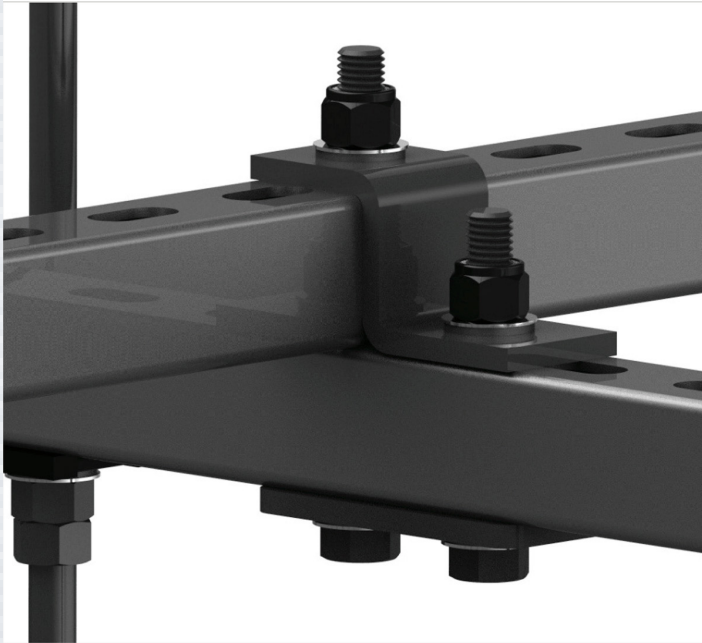

### STRUT FITTING

This complete cross-over kit provides all the necessary hardware to clamp two channel strut sections together perpendicularly, one over the other. This kit allows for a fast, secure method of clamping these structural sections together to assemble larger fabrications. Non-loosening and sound isolated hardware is included to assure a firm, long lasting and sound dampened connection.



### KEY FEATURES:

- ▶ Creates 90 degree junction for strut
- ▶ Secure and load-rated
- ▶ Fast easy installation
- ▶ Vibration isolating components

### OPTIONAL ACCESSORIES:

- ▶ See Strut Accessories Datasheet
- ▶ See Threaded Rod Datasheet
- ▶ See Threaded Pipe Datasheet

### SPECIFICATIONS:

**Material:** Structural Steel

**Finish:** Bright Zinc

**Color:** Silver

**Design Factor:** XXXXXXX

**WLL:** 779 lbs / 354 Kg.

(Assembly Rating)

**Shipping Weight:** 1.6 lbs / .73 Kg.

### PACKAGE CONTENTS:

**1 pc** Z Shaped Bracket

**1 pc** 1/2-13 Hex Bolt x 5" Long

**1 pc** 1/2-13 Hex Bolt x 3 1/2" Long

**4 pcs** Sound Isolation Washers

**2 pcs** 1/2-13 Nyloc Hex Nuts

**1 pc** Flat Capture Plate



Rated for indoor use.

**Z Bracket  
CG-P1045-ZB  
Side View**

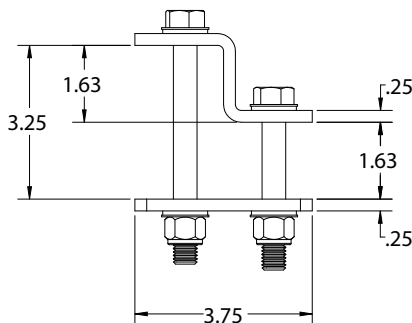

### DIMENSIONS:

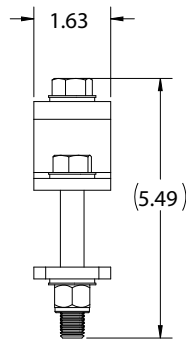

### Top View

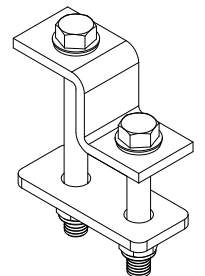
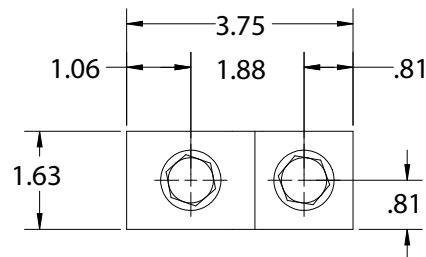

**Adaptive Technologies Group**  
1635 E. Burnett Street | Signal Hill, CA 90755 USA  
Ph: 562.424.1100 | Fax: 562.424.3520  
www.adaptivetechgroup.com



### ALWAYS INSTALL SAFETY CABLES

**WARNING:** Mounting and/or suspension of equipment requires experienced professionals. Improperly installed equipment can result in property damage, personal injury and/or liability to the installing contractor.