

EL-315

2500 lb WLL

5/16" OVAL SHAPED END LINK

END LINK



Weldless End Link

Weldless endlinks are produced from a single piece of metal so there is no chance for weld failure. This high strength load-rated link is ideal for use in coupling multiple span sections together, such as wire rope and rigging chain. Multiple sections of wire rope and rigging chain link together, using shackles. Its oval shape is designed for in-line use and is not to be side loaded.

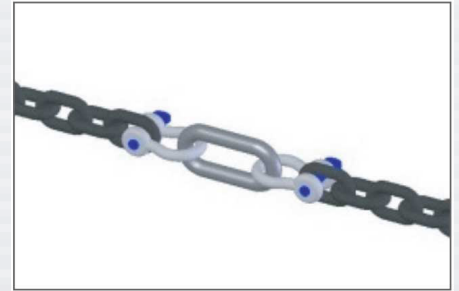

In-Line Rigging

KEY FEATURES:

- ▶ High Strength
- ▶ Weldless

OPTIONAL ACCESSORIES:

- ▶ See SK Series Shackles
- ▶ See QL Series Quick Links

SPECIFICATIONS:

Diameter: 5/16"
Material: Forged Carbon Steel
Finish: Galvanized
WLL: 2500 lb / 1136 Kg
Design Factor: 5:1

PACKAGE CONTENTS:

1pc 5/16" End Link



DIMENSIONS:

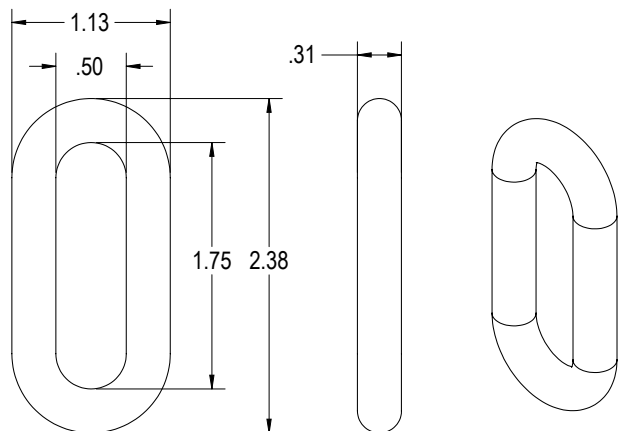

ALWAYS INSTALL SAFETY CABLES

WARNING: Mounting and/or suspension of audio and video equipment requires experienced professionals. Improperly installed loudspeakers can result in property damage, personal injury and/or liability to the installing contractor.