

HoverTrack™

4 Wide x 4 Deep Video Wall Display Installation Guide

VWD-4X4-UD55A

This display kit mounts Samsung UD55A LCD monitors in a 4 wide by 4 deep landscape configurations. The frame attaches to a wall and receives the LCD monitors by way of four machined fittings (per monitor) that thread into the monitor's VESA holes. These fittings then insert into the frame's channels. The monitor's fittings secure to the frame with locking arms that provide an easy way to remove the monitors for service. A removable panel provides access for media players behind the frame.

Important: Installing video displays is a serious endeavor that requires experienced professionals. **Improperly prepared walls and other structures as well as the equipment being installed can result in property damage, injury, death and/or liability to the installing contractor.** Do not proceed if any part of the installation is in doubt.

Caution: Due to the wide variety of structures, environments, materials and installation methods, the installing contractor must exercise good judgment in selecting the proper mounting area. The mounting structure must be capable of supporting at least 5 times the load of the installed equipment. Consult local building codes for further guidance.

Follow these instructions for the most efficient and safest mounting results.

Package Contents:

- 1 pc Upper Frame Assembly w/ locking arms
- 1 pc Lower Frame Assembly w/ locking arms
- 7 pcs Vertical Joiner bracket
- 64 pcs Adjustable VESA button (black)
- 42 pcs Adjustable Lag bolts, 5/16"
- 42 pcs Hex nuts, 5/16"
- 42 pcs Flat washer, 5/16"
- 1 pc Instruction sheet

Notes:

Hardware to mount frames to wall is included.

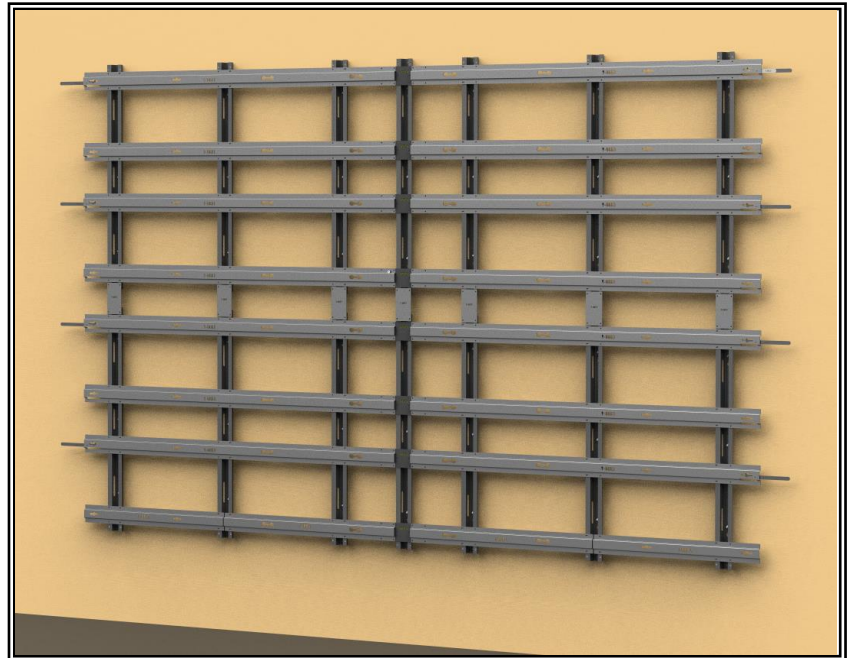

4 Wide x 4 Deep Video Wall Display (Rear View)

Step 1: Mount Upper Frame to Wall

Scribe a horizontal line on the wall showing the exact location of where the top edge of the upper left monitor will be. Measure down 9.1" (231mm) from that line and scribe another horizontal line showing where the horizontal location of the first adjustable lag bolt will be (Figure 1).

Scribe a vertical line showing where the top left side of the upper monitor will be. Measure to the right 16.9" (429.3mm) and scribe another vertical line showing where the vertical location of the first adjustable lag bolts (Figure 1). Mark the intersection of the vertical and horizontal lines.

Measure 157.7" (4005.6mm) to the right for the location of the second adjustable

lag bolt. Use a long level to make sure the second location is horizontally aligned to the first lag bolt location (Figure 1). Mark the second lag bolt location.

Measure 76.9" (1953.3mm) to the right for the third adjustable lag bolt. Mark the third lag bolt location (Figure 1).

Pre-drill the marked lag bolt locations using a 3/16" or 5mm drill bit.

Install the first, second and third adjustable lag bolts to the pre-drilled holes until the hex part of the bolt is flush to the wall. A deep socket wrench maybe required.

Step 2:

Hang the upper frame to the adjustable lag bolts (Two or three people required). Install the provided hex nut and flat washer, level upper frame then tighten the hex nuts.

Use the frame as a template to mark the other locations of the adjustable lag bolts. Use three (3) per vertical channel, two keyholes and the center hole (Figure 2).

Loosen and remove the hex nut and flat washer securing the upper frame to the wall. Place the upper frame back on the floor. Pre-drill marked holes using the 3/16" or 5mm drill bit then install the other adjustable lag bolts until the

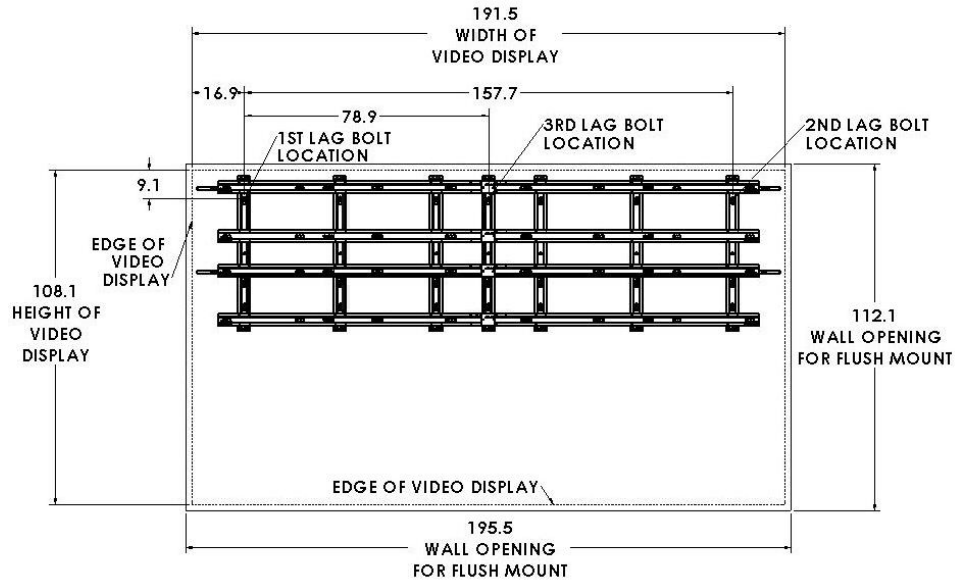

Figure 1

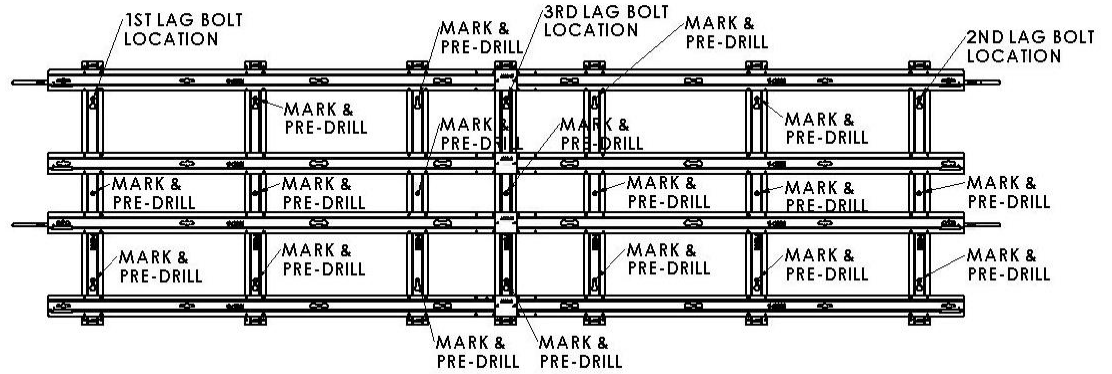

Figure 2

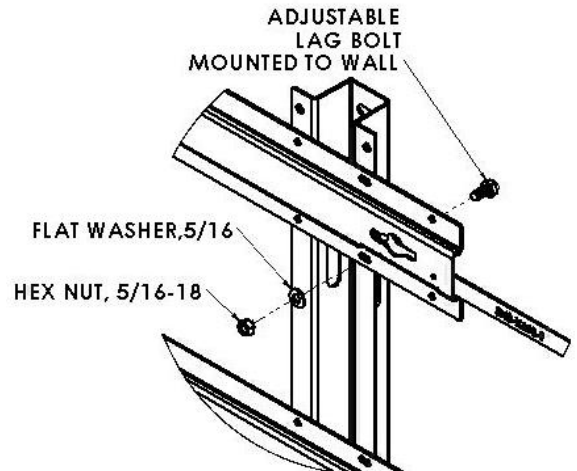

Figure 3

hex part of the bolt is flush to the wall (**Figure 2**). Hang the upper frame onto the adjustable lag bolts mounted on the wall. Install hex nut and flat washer then snugly tighten hex nuts. **DO NOT TIGHTEN** permanently until the entire video frame is installed and adjusted (**Figure 3**).

Step 3: Attach Lower frame to Upper Frame

Align vertical joiner brackets from the lower frame to the bottom of the upper frame's vertical channel holes then secure using the supplied M6 flat head screws (**Figure 4**). Snugly tighten screws only. **Connect only the center and the side vertical joiner plates.**

Mark the locations of the adjustable lag bolts for the lower frame. Three per V-Channels (**Figure 2**). Detach the lower frame from the top frame by unscrewing the screws on the Vertical joiner plate then place lower frame back on the floor.

Pre-drill marked location using a 3/16" or 5mm drill bit then install the adjustable lag bolts until the hex part is flushed with the wall.

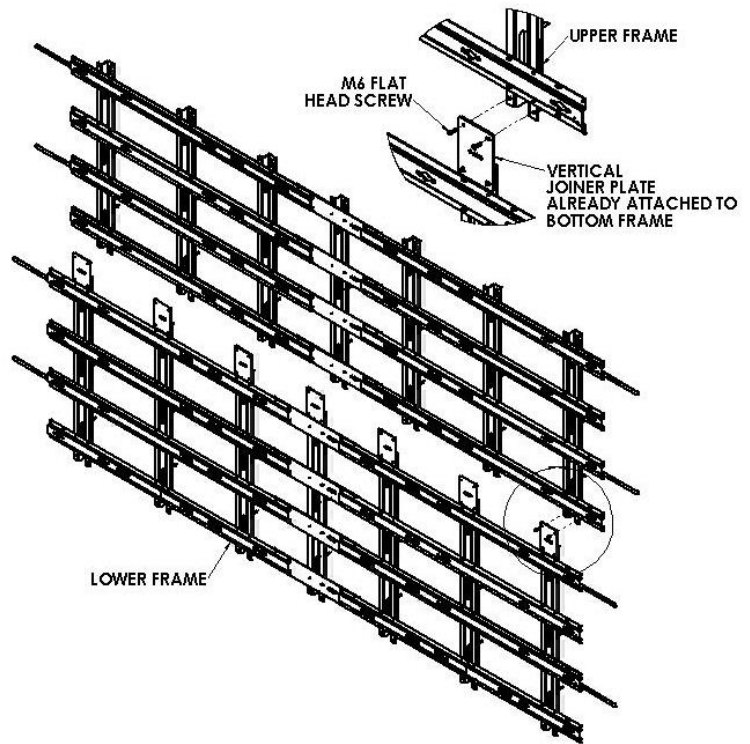

Figure 4

Step 4:

Hang the lower frame to the adjustable lag bolts on the wall then connect all the vertical joiner plates to the bottom of the upper frame. Tighten screw permanently. Install the flat washer and hex nut onto the adjustable lag bolts then snugly tighten (**Figure 4**).

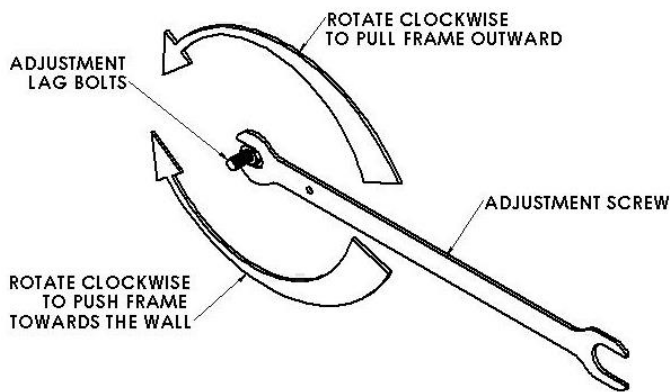

Figure 5

Step 5:

Use a long level to plum the frame by rotating the adjustable lag bolts on the V-channels using the provided adjustment wrench starting from one side of the frame. Rotate counter clockwise to pull the frame forward and clockwise to push the frame back towards the wall (**Figure 5**). Use a long level, a straight edge or a piece of string secured on each side of the frame to make the horizontal H-slat straight by adjusting the adjustable lag bolts closest to the H-slat. Once the frame is plumbed and leveled, tighten all hex nuts permanently.

Step 6: Optional

Install Brackets to Media Player (Brackets not included)

Attach the media player brackets to the sides of the media player using its existing side screws. Media player varies in sizes (**Figure 6**).

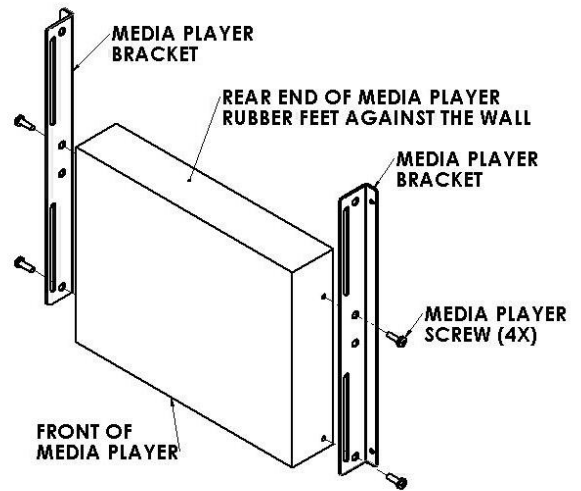

Figure 6

**Step 7: Optional
Install Media Player**

Choose and remove the bottom left or right lower side H-slat by unscrewing its flat head screws (**Figure 7**). Install the media player to the wall in between the two vertical V-channels using the appropriate fasteners for the media player's bracket. Re-install the bottom lower side H-slat (**Figure 7**).

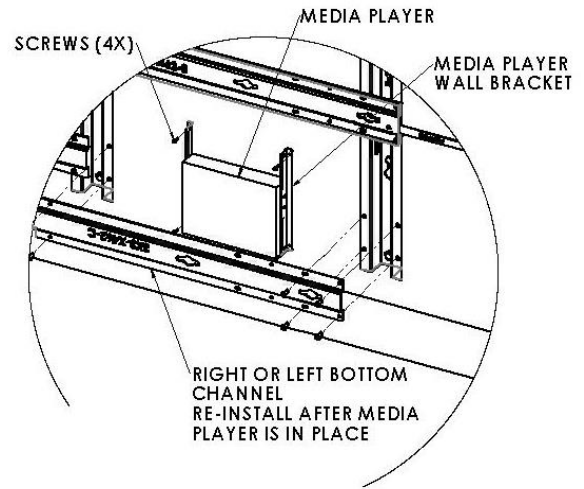

Figure 7

Step 8: Install M8 VESA buttons to monitors

Thread the M8 adjustable VESA buttons to the VESA mounting holes in the back of each monitor (**Figure 8**).

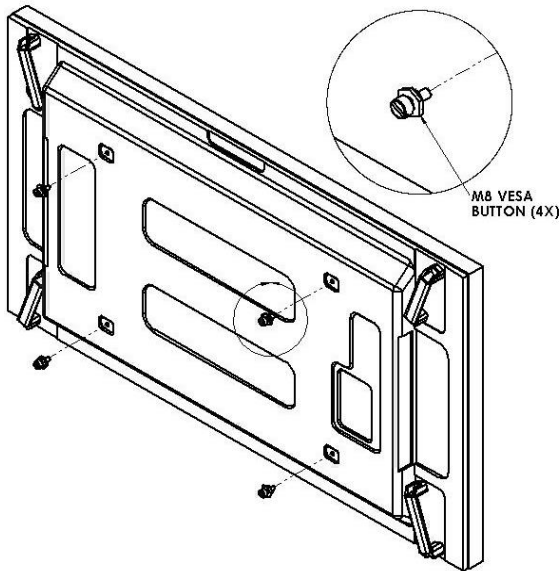

Figure 8

Step 9: Install Monitors to the Left Column

Lift up the locking arms on the left side of the frame. Starting with the upper left monitor, connect power and signal wires to each monitor then align its four Adjustable VESA buttons with the four large slots in the H-slats then slide the monitor from left to right until it stops. Pull down the locking arm to lock monitor into place (**Figure 9**). Repeat step 9 for the three lower monitors.

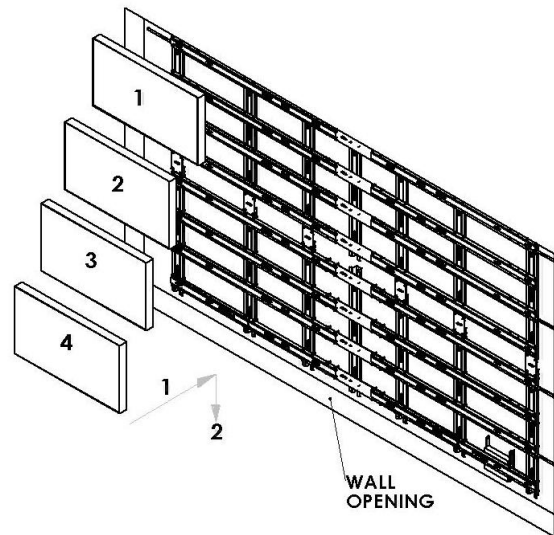

Figure 9

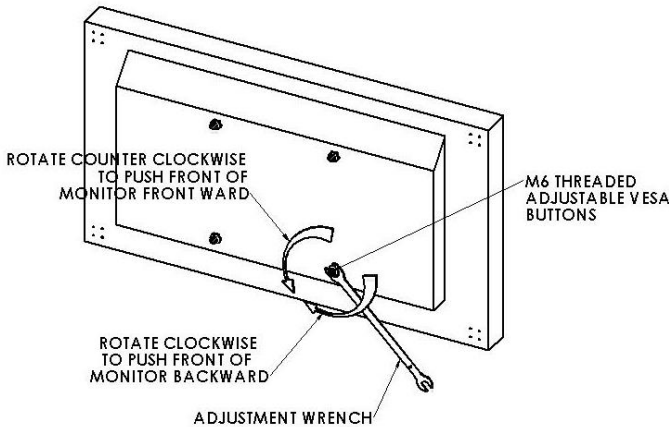

Figure 10

Step 10: Note on alignment:

While installing monitors, check for front and side alignment of the monitors. The surfaces of all monitors must be aligned and flush to each other. If one or more screens are tilted more than others use the adjustment wrench to reach the hex portion of the M8 adjustable VESA buttons at the rear of the monitor and rotate counter clockwise to pull the front of the monitor forward or clockwise to push it back towards the wall. If access to the rear is not accessible remove the screen(s) and depending whether the monitor needs to be tilted forward or backward rotate the buttons using the adjustment wrench, a flat head screw driver or fingers (**Figure 10**). Reinstall and recheck surface alignments. Repeat where necessary.

Step 11: Install Second Column Monitors

Starting with the top monitor, connect the power and signal wires to each monitor then align its four M8 adjustable VESA buttons with the four large slots in the H-slats. Slide the monitor from right to left until it is snug against the left column monitor (**Figure 11**). Repeat step 11 for the three lower monitors. Check for front and side alignments-refer to Step 10.

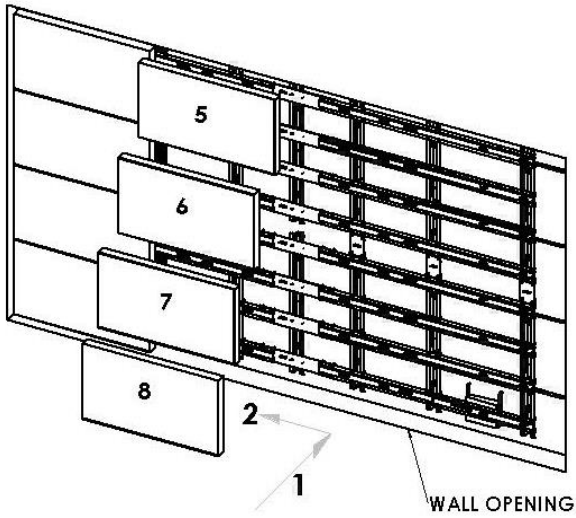

Figure 11

Step 13: Install Third Column Monitors

Repeat step 11 to install the third column monitors.

Step 14: Install Fourth Column Monitors

Lift up the locking arms on the right side of the frame. Starting with the upper monitor, connect power and signal wires to each monitor then align its four M8 adjustable VESA buttons with the four large slots in the H-slats. Slide the monitor from right to left until it is snug against the next column monitor. Pull down the locking arm to lock monitor into place (**Figure 12**). Repeat step 12 for the lower three monitors. Check for front and side alignments. Refer to Step 10.

Servicing Tips

First (Left) Column Monitor Removal

Reach fingers between the wall and the monitor and lift the locking arm to unlock. Slide monitor to the left about 1.00" (25.4mm) until its VESA buttons disengage from the frame, lift a little to support the weight of the monitor then slowly pull to remove (**Figure 13**).

Second Column Monitor Removal

Reach fingers between the left-side wall and the monitor to the left of the monitor being removed. Lift the locking arm to unlock then slide the monitor to its extreme left position, about 1.5" (40 mm.) Slide the second column monitor to the left until its VESA buttons disengage from the frame, lift a little to support the weight of the monitor then slowly pull to remove.

Third Column Monitor Removal

Reach fingers between the right side wall and the monitor to the right of the monitor being removed. Lift the locking arm to unlock then slide the monitor to its extreme right position, about 1.5" (40 mm). Slide the third column monitor to the right until its VESA buttons disengage from the frame, lift a little to support the weight of the monitor then slowly pull to remove.

Fourth (Right) Column Monitor Removal

Reach fingers between the wall and the monitor and lift the locking arm to unlock. Slide the monitor to the right until its VESA buttons disengage from the frame, lift a little to support the weight of the monitor then

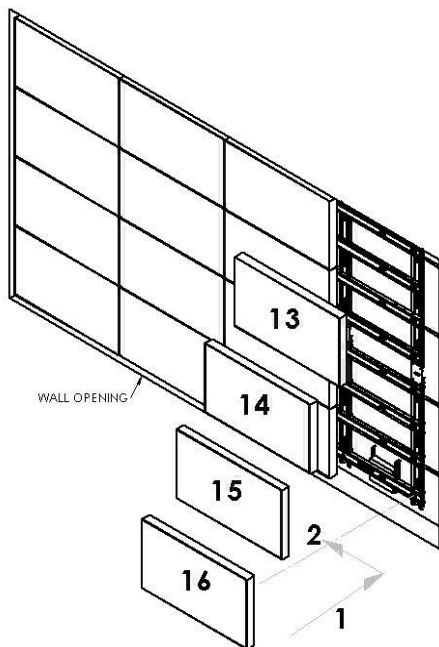

Figure 12

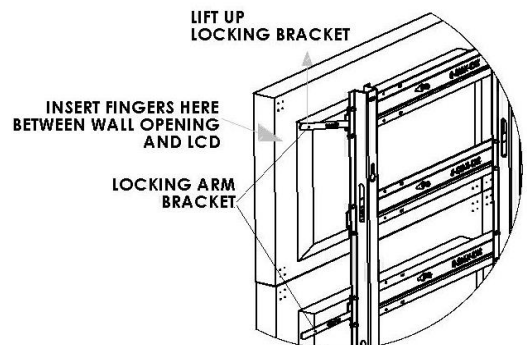

Figure 13

slowly pull to remove (**Figure 13**).